

ROLTEX TR 2100 RETRACTABLE SUNROOF SYSTEM SPECIFICATIONS

Please note illustrations are not to scale. All measurements are in millimetres. Please contact your Tecnic representative for additional information.

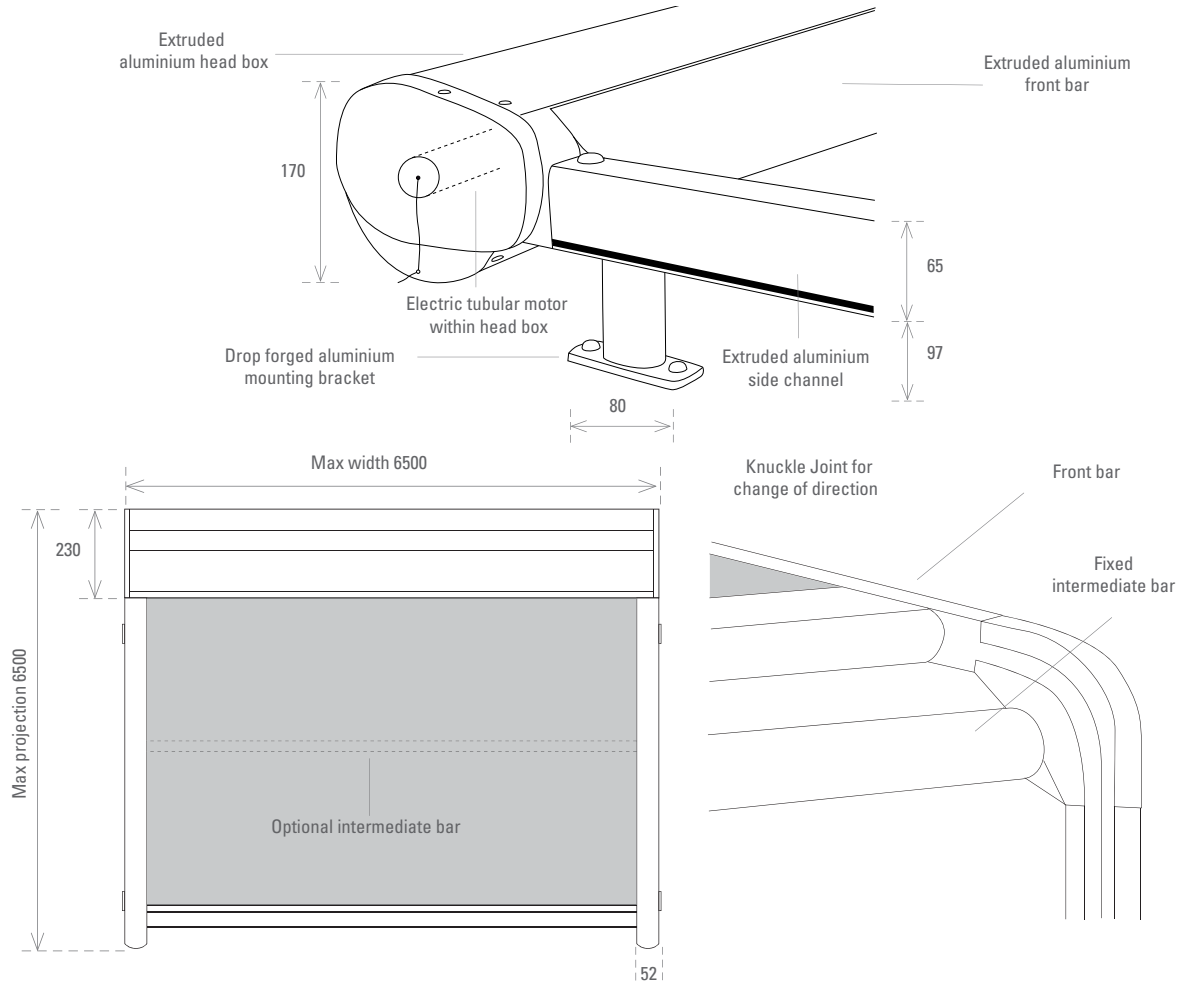

SIZES		
WIDTH	Min 1500mm Max 6500mm	
PROJECTION	Min 1400mm Max 6500mm	
COLOURS		
STANDARD	White RAL 9016/White Aluminium RAL 9006/Black RAL 8022	
OPTIONAL	Over 300 optional custom RAL colours available	
OPERATION		
ELECTRICAL	Somfy electric tubular motor-remote-sun-wind & timers	
SIDE CHANNELS		
MATERIAL	Powder coated 6061 grade extruded aluminium with Kevlar reinforced belt drive mechanism within channel	
SIZE	65mm x 52mm	
HEAD BOX		
MATERIAL	Powder coated 6061 grade extruded aluminium	
SIZE	170mm x 200mm	
TOP ROLLER		
MATERIAL	Heavy duty extruded roller tube	
DIAMETER	85mm	
FRONT BAR		
MATERIAL	Powder coated 6061 extruded aluminium	
SIZE	120mm x 68mm	
MOUNTING BRACKETS		
MATERIAL	Drop forged aluminium with stainless steel key connections	
FABRIC		
MARINE GRADE ACRYLIC	100% dope dyed acrylic "Sunacrylic" fibre-orchestra	
SUNSCREEN MESH	High tenacity polyester core yarn sunscreen - Soltis 86 (15% openness) 92/93 (5% openness) ranges	
STANDARD COLOUR OPTIONS OR CUSTOM COLOUR ON REQUEST		
White/RAL 9016	White Aluminium/RAL 9006	Black/RAL 8022

P 1300 832 642
E action@tecnic.com.au

3 / 87 Reserve Rd
Artarmon NSW 2064

www.tecnic.com.au

TECNIC